

UTRUSTA

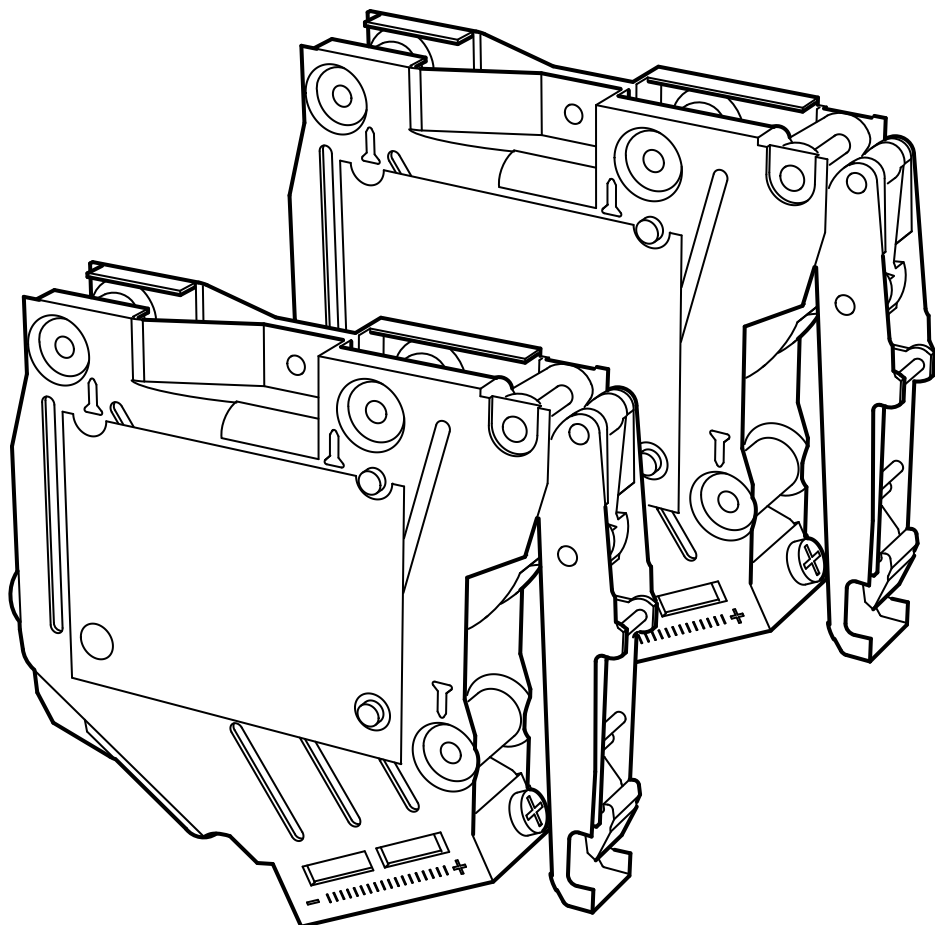

Design and Quality
IKEA of Sweden

**ENGLISH**

Warning!
Take care when handling this hinge as the spring is very strong and can cause injury.

DEUTSCH

Achtung! Bitte Vorsicht beim Umgang mit diesem Scharnier. Die stark gespannte Feder könnte zu Verletzungen führen.

FRANÇAIS

Attention !
Prenez garde lorsque vous manipulez cette charnière car le ressort est très tendu et risque d'occasionner des blessures.

NEDERLANDS

N.B. Wees voorzichtig bij het monteren van deze scharnier. De veer is zeer krachtig en kan letsel veroorzaken.

DANSK

ADVARSEL!
Hængslet skal håndteres forsigtigt, da fjederen er meget stærk og kan forårsage personskade.

ÍSLENSKA

Viðvörðun!
Gætið varkárni þegar þessar lamir eru meðhöndlaðar því gormurinn er mjög sterkur og getur valdið meiðslum.

NORSK

Advarsel!
Vær forsiktig når du håndterer disse hengslene, ettersom fjæren er sterk og kan forårsake personskader.

SUOMI

Varoitus!
Olethan varovainen käsittellessäsi tätä saranaa, sillä jousi on erittäin jäykkä ja voi aiheuttaa vammoja.

SVENSKA

Obs! Var försiktig när du handskas med det här gångjärnet. Fjädern är mycket kraftig och kan skada dig.

ČESKY

Upozornění!
S pantem zacházejte opatrně - pružina uvnitř je velice silná a může způsobit zranění.

ESPAÑOL

iAtención!
Ten cuidado al manipular esta bisagra, porque el muelle está muy tensado y puede causar lesiones.

ITALIANO

Avvertenza! Fai attenzione quando maneggi questa cerniera: la molla è molto tesa e può rischiare di causare lesioni.

MAGYAR

Figyelem!
Óvatosan bánj a zsanérral, mert a rugó nagyon erős, és sérülést okozhat.

POLSKI

Ostrzeżenie!
Montując zawias zachowaj ostrożność, ponieważ sprężyna jest bardzo mocna i może powodować obrażenia.

LIETUVIŲ

Įspėjimas!
Būkite atidūs dirbdami su šiais lankstais. Spyruoklė labai tampri ir gali sužeisti.

PORTUGUÊS

Aviso!
Tenha atenção ao manipular esta dobradiça pois a mola é muito forte e pode causar lesões.

ROMÂNĂ

Atenție!
Ai grijă când montezi balamaua pentru că arcul este foarte puternic și te poate răni.

SLOVENSKY

Upozornenie!

Pri zaobchádzaní s týmto pántom buďte opatrný, pretože pružina je veľmi silná a môže spôsobiť zranenie.

БЪЛГАРСКИ

Внимание!

Бъдете предпазливи при работа с тази панта, тъй като пружината ѝ е много здрава и може да причини нараняване.

HRVATSKI

Upozorenje!

Pripazite prilikom rukovanja ovom šarkom. Opruga je jako čvrsta i može izazvati ozljede.

ΕΛΛΗΝΙΚΑ

Προειδοποίηση!

Προσέχετε όταν χειρίζεστε αυτόν τον μεντεσέ, διότι το ελατήριο είναι πολύ δυνατό και μπορεί να προκαλέσει τραυματισμό.

РУССКИЙ

Внимание!

Будьте осторожны при обращении с этой петлей, так как пружина очень прочная и может причинить вред.

SRPSKI

Upozorenje!

Pažljivo rukujte ovim šarkama jer je opruga veoma jaka i može izazvati povredu.

SLOVENŠČINA

Opozorilo!

Pri ravnanju s to odmično spono bodite zelo previdni, saj je vzmet zelo močna in lahko povzroči telesne poškodbe.

TÜRKÇE

Uyarı!

Yayın çok güçlü olduğunu ve yaralanmalara sebep olabileceğini dikkate alarak menteşe ile çalışırken dikkatli olunuz.

中文

警告！

处理合叶时应小心谨慎，弹簧力度很强，可能会导致受伤。

繁中

警告！

請小心使用鉸鏈·因彈簧的彈力強·可能會造成傷害。

한국어

경고!

경첩을 다룰때 강한 스프링으로 인해 부상의 위험이 있으므로 주의해 주세요.

日本語

警告！

このヒンジは固いので、指などを挟まないよう、お取り扱いには十分ご注意ください。

BAHASA INDONESIA

Peringatan!

Berhati-hati ketika mengendalikan engsel karena pegas yang kuat dan dapat menyebabkan cedera.

BAHASA MALAYSIA

Awas!

Berhati-hati semasa mengendalikan engsel kerana springnya amat kuat dan boleh menyebabkan kecederaan.

عربي

تحذير!

احذر عند مناولة هذه المفصلة حيث أن النابض قوي جداً وقد يسبب إصابات.

ไทย

คำเตือน

ระวังขณะจับหรือใช้งานบานพับ เนื่องจากสปริงของบานพับแข็งมากจนอาจทำให้เกิดอันตรายได้

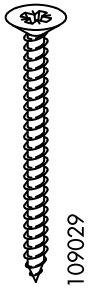
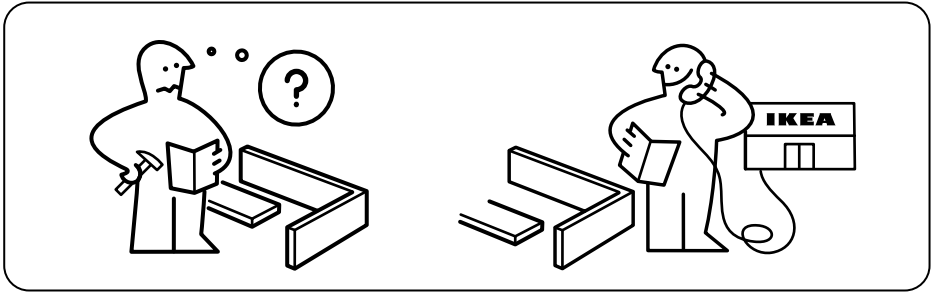
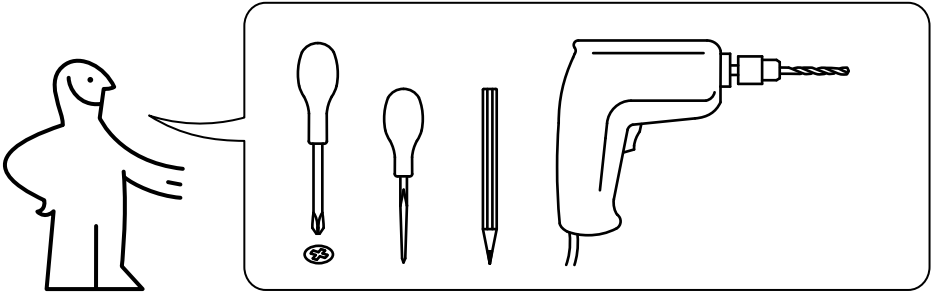

6x



4x

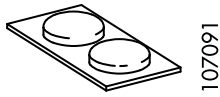

1x

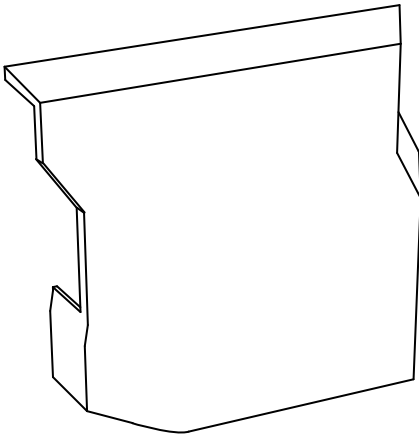

128853
128852

1x

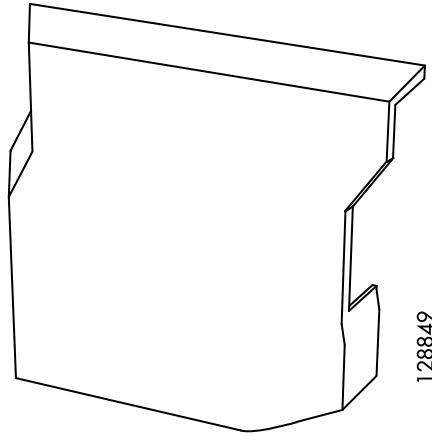

128849
128848

1x

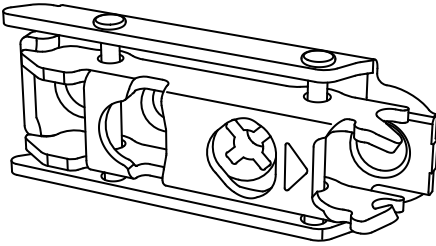

128584

2x

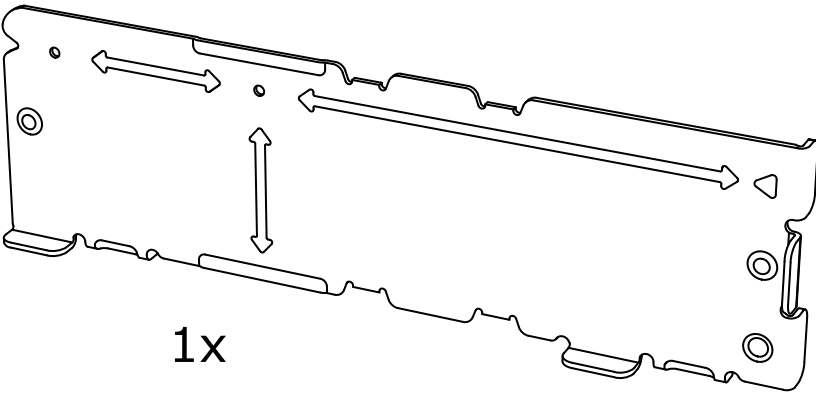

128586

1x

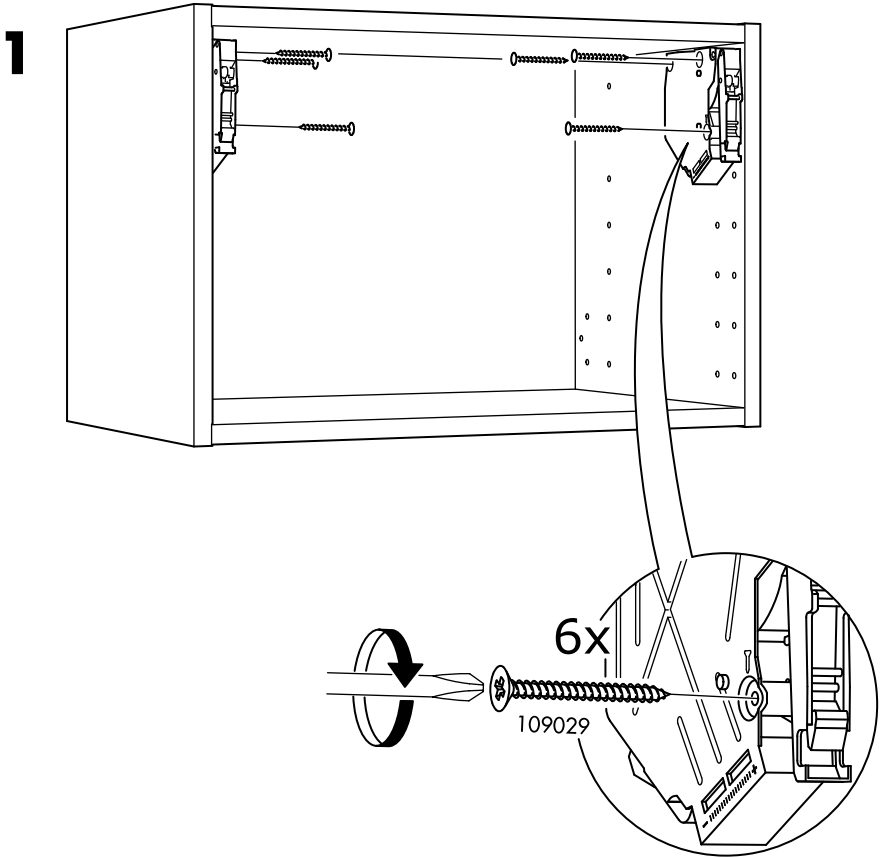
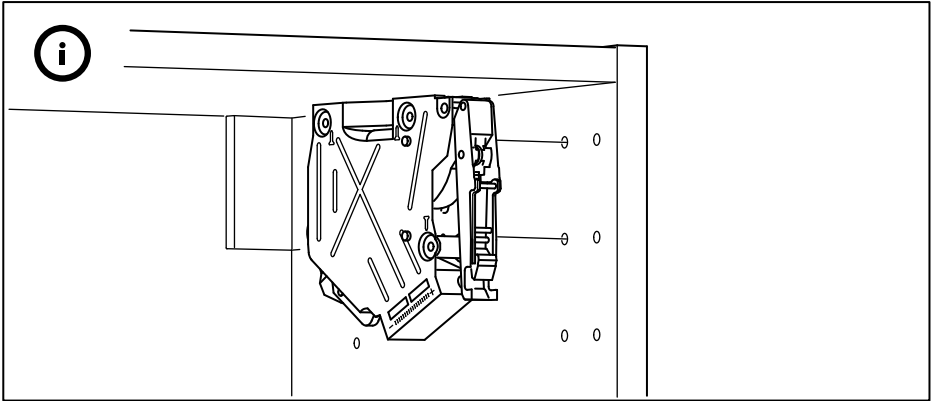

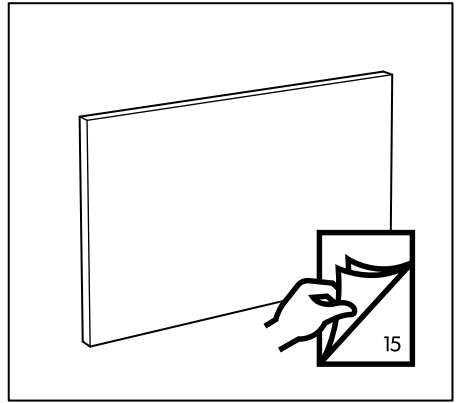
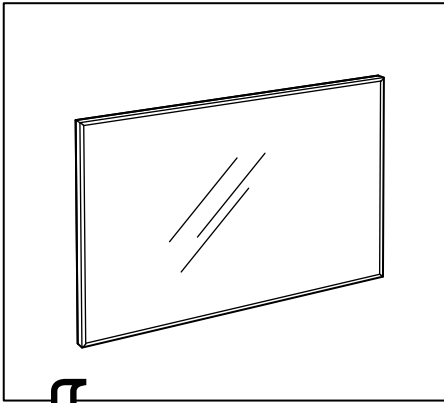

2

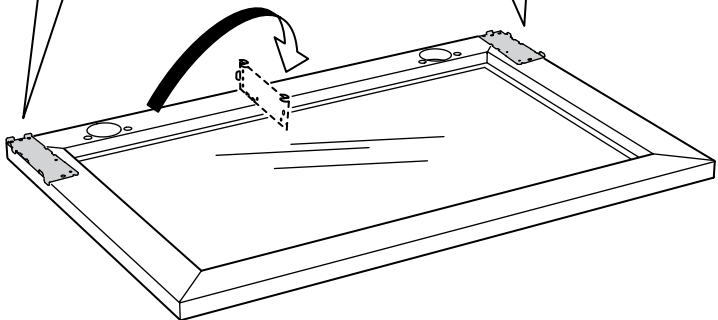
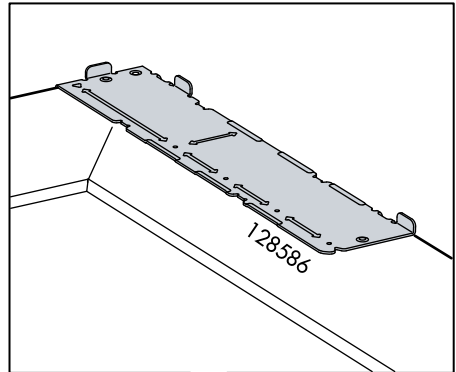
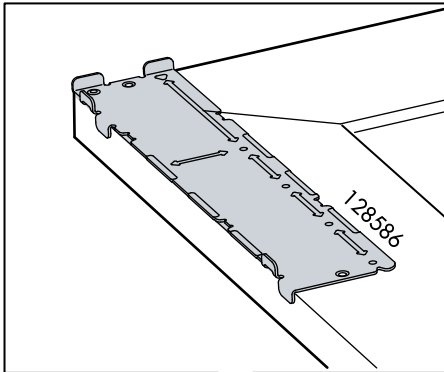

3

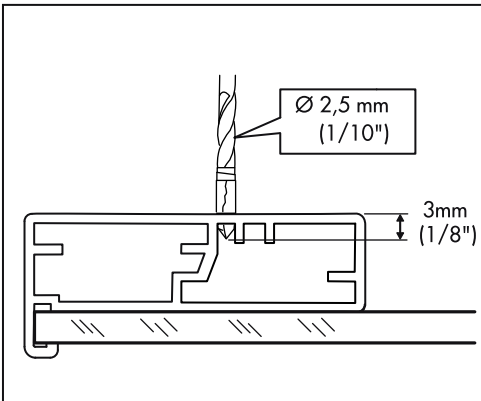
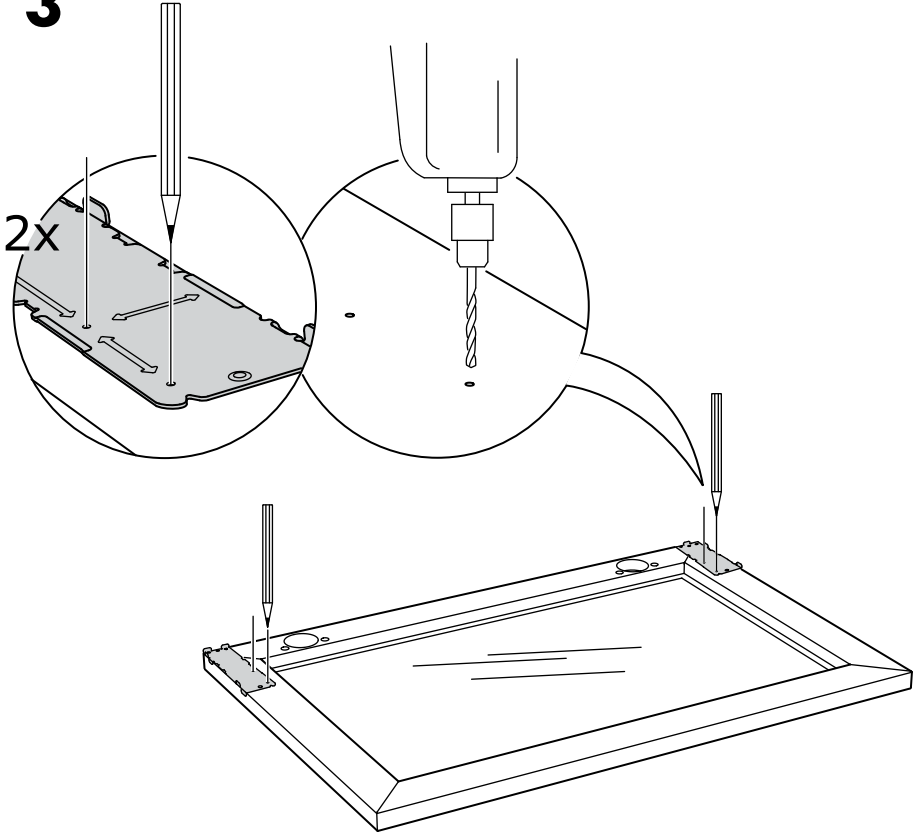

4

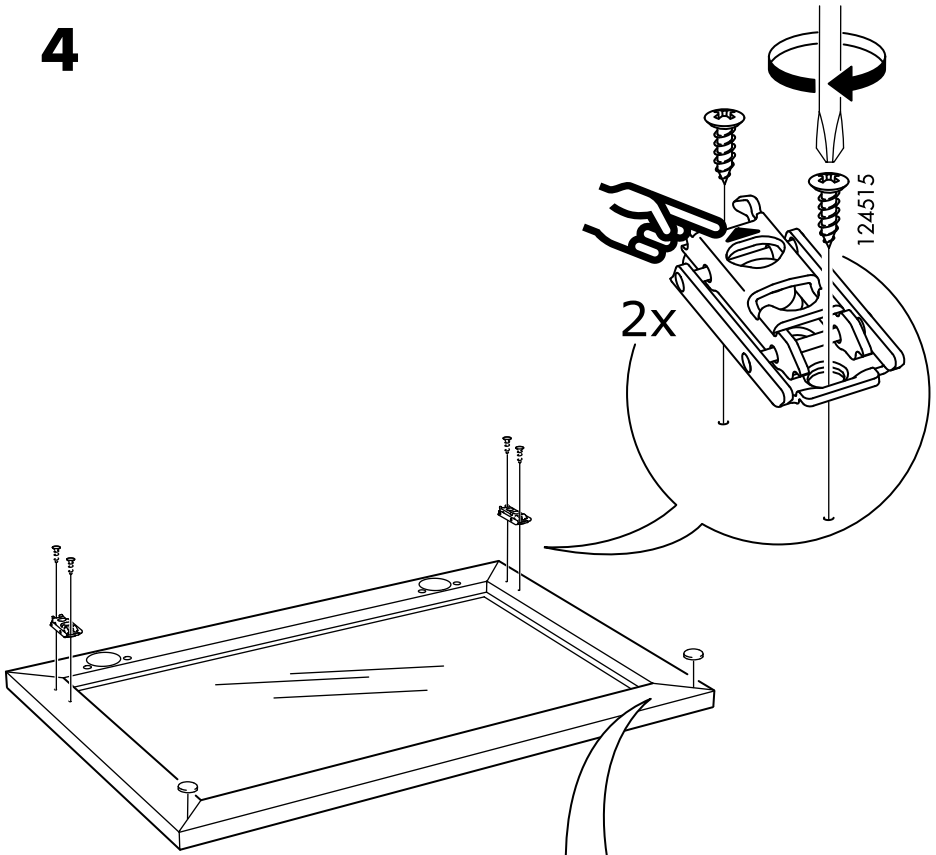

5

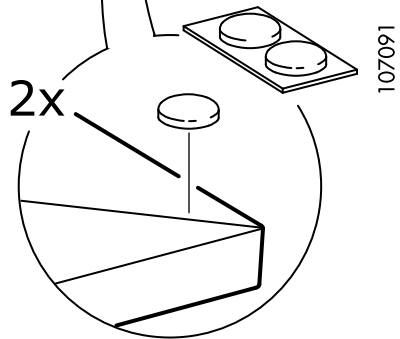

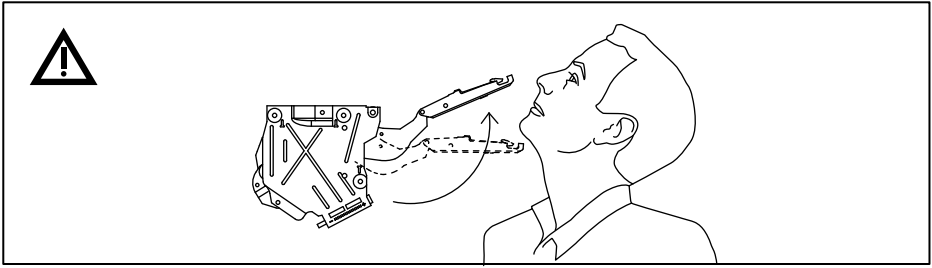

6

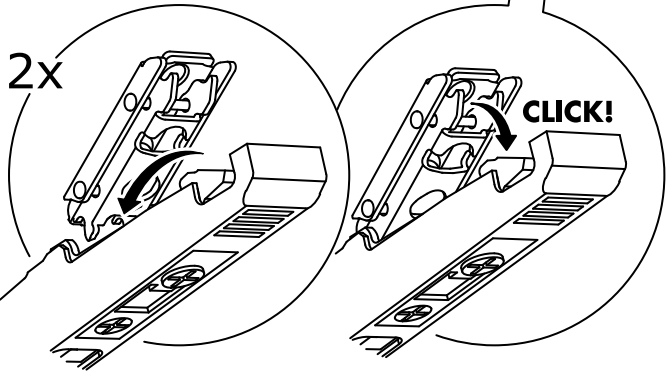
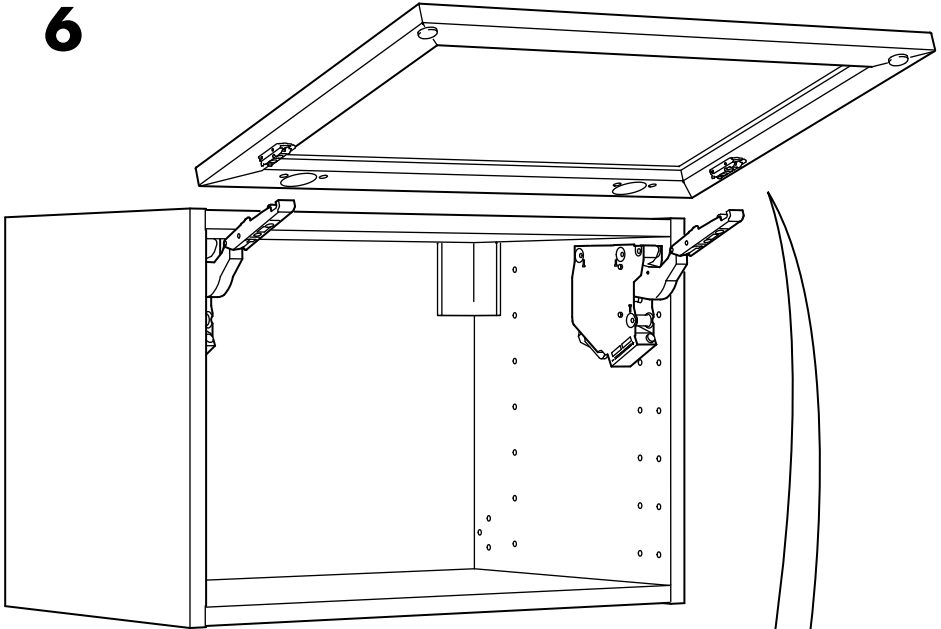

7

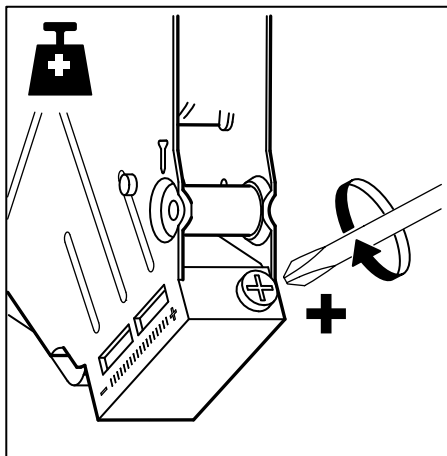
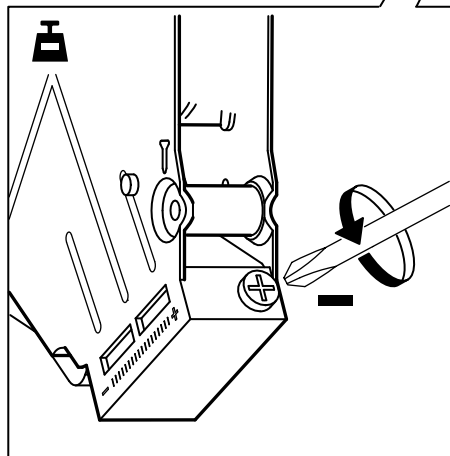
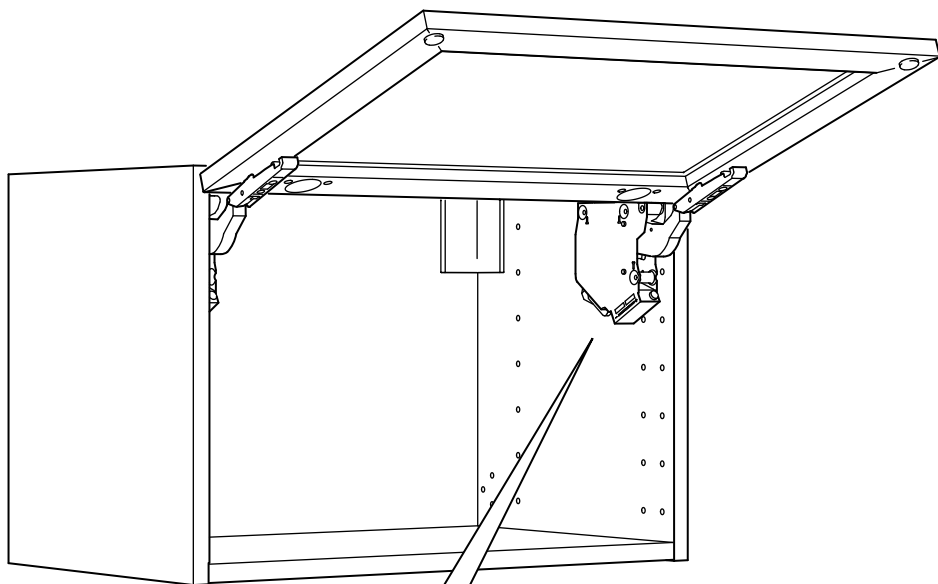

8

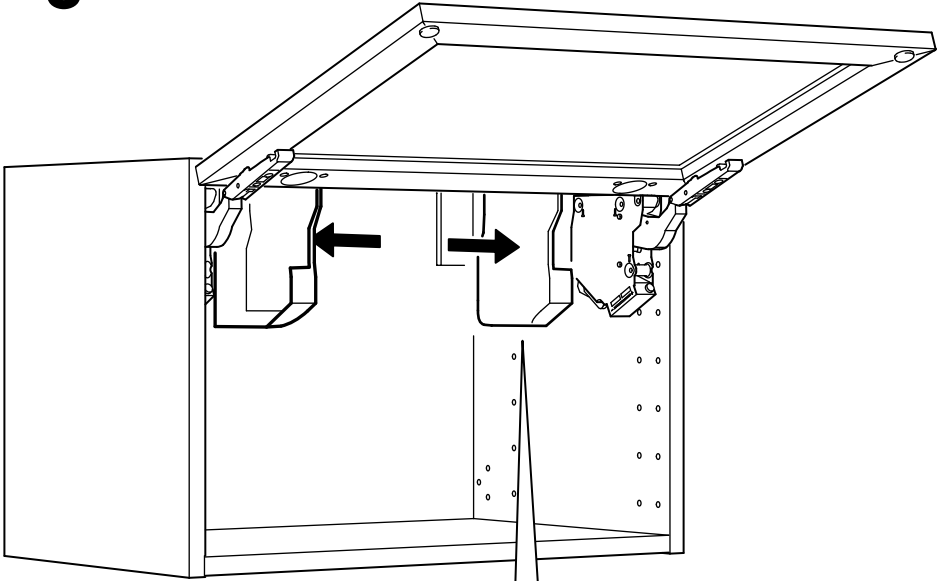

2x

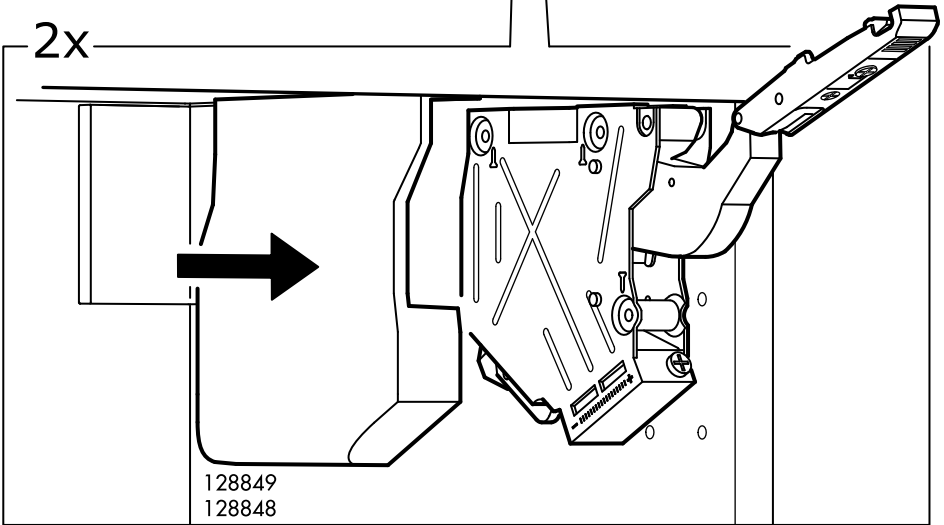

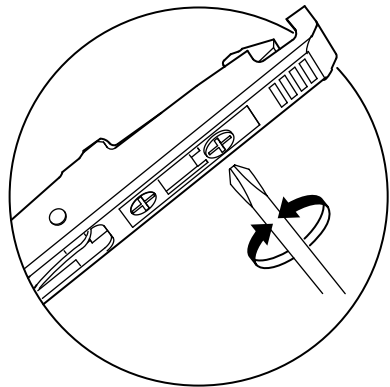
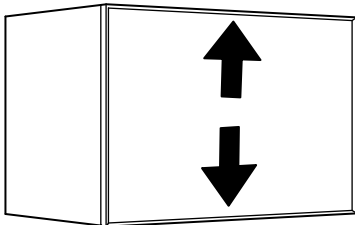
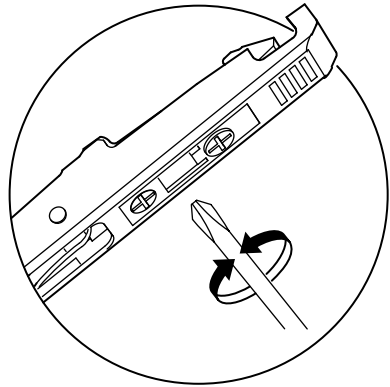
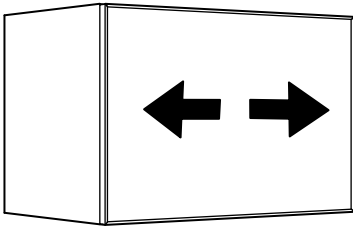
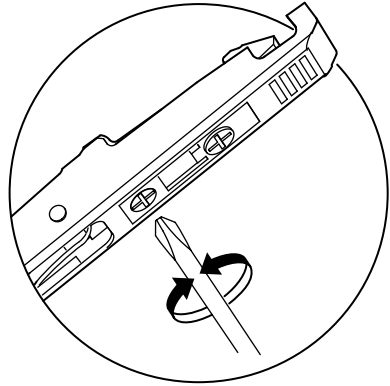
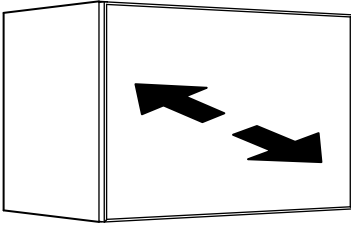

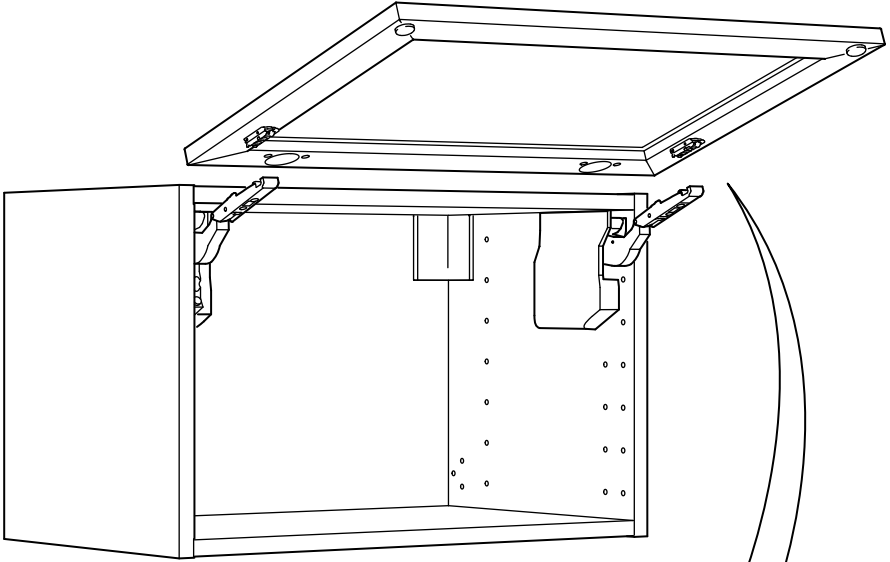
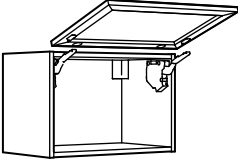

2x

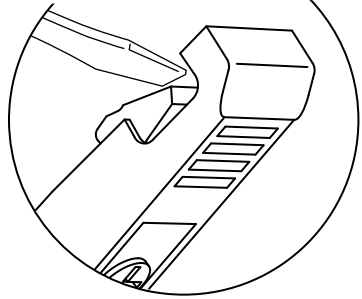

2

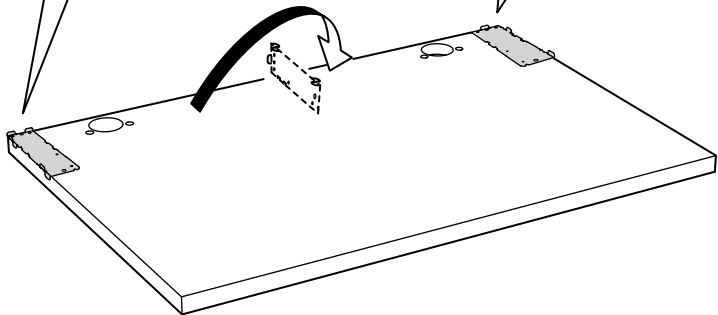
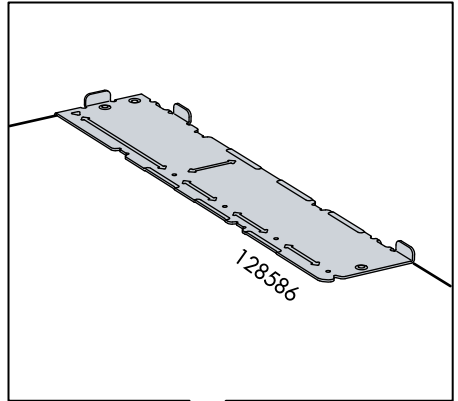
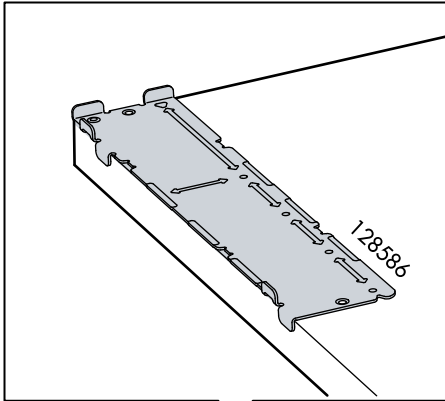
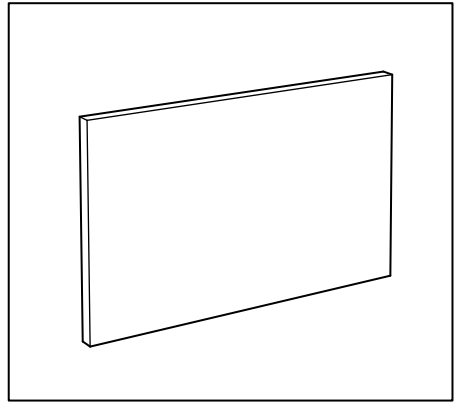

3

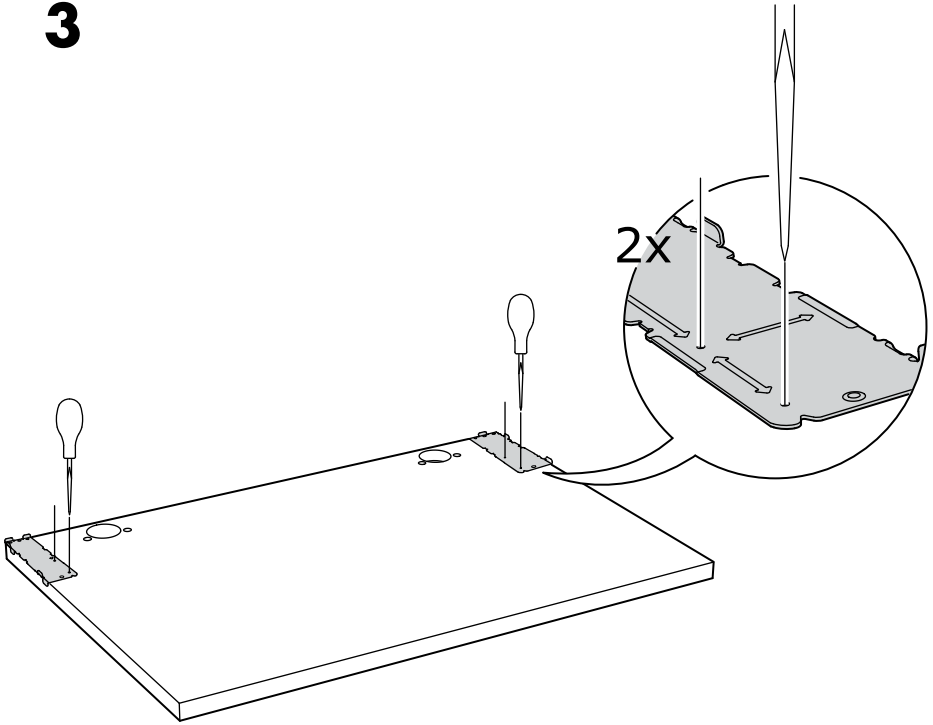

4

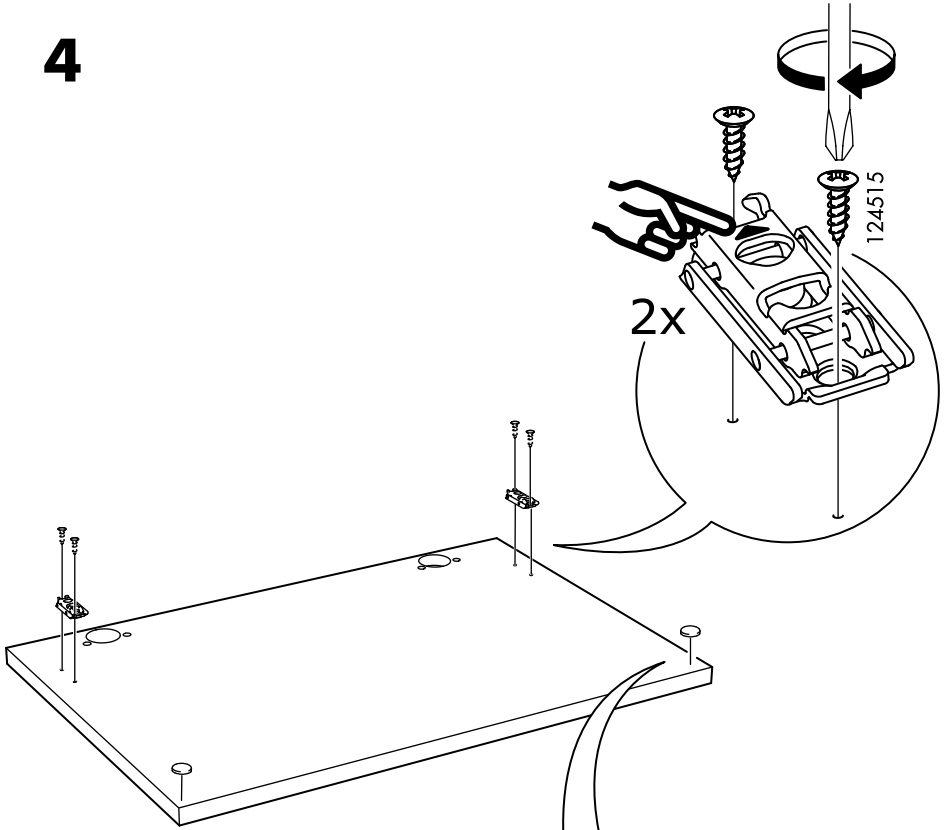

5

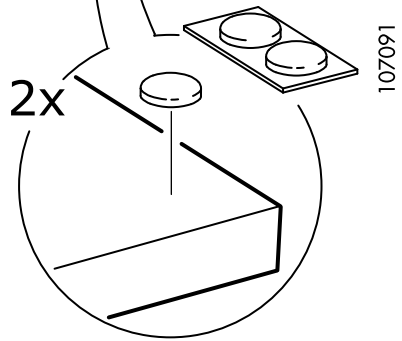

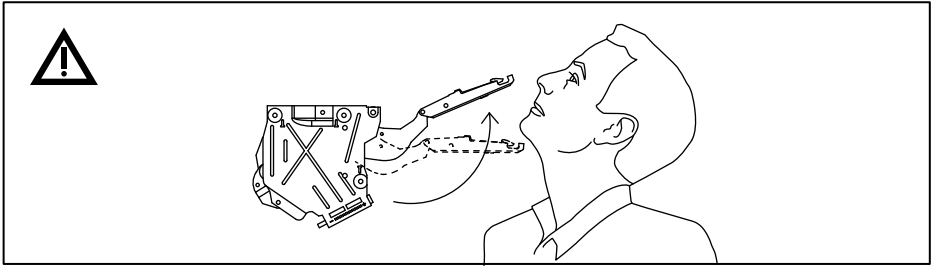

6

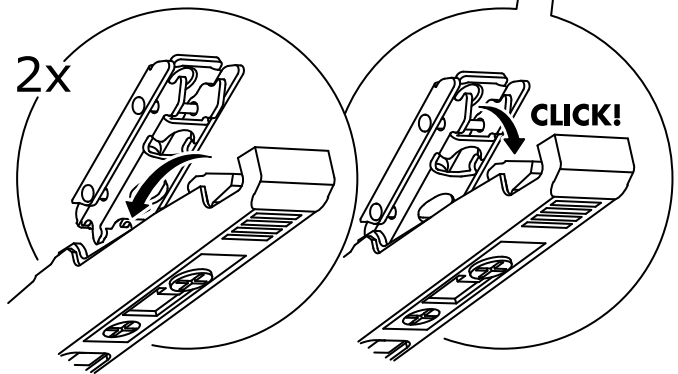
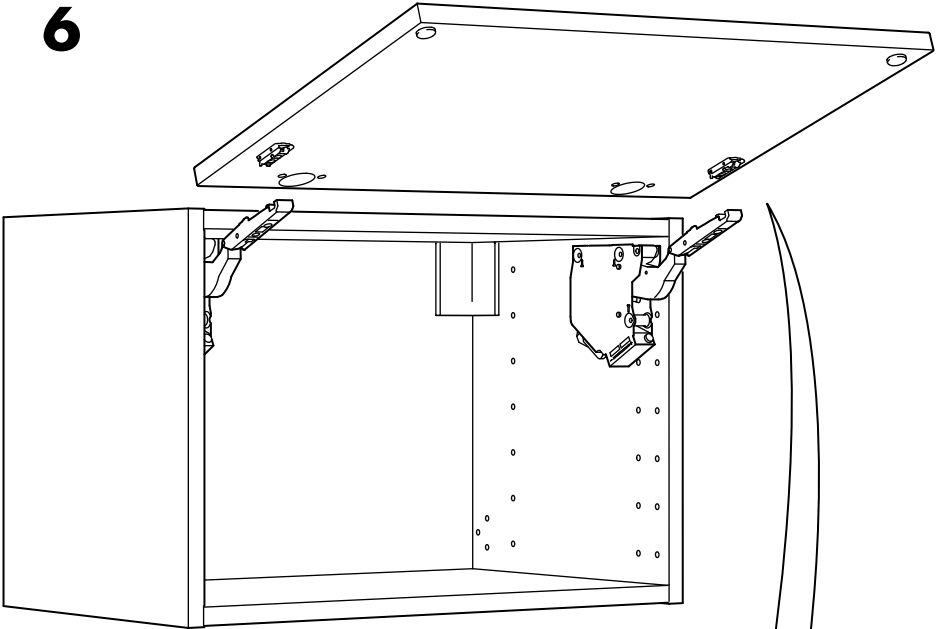

7

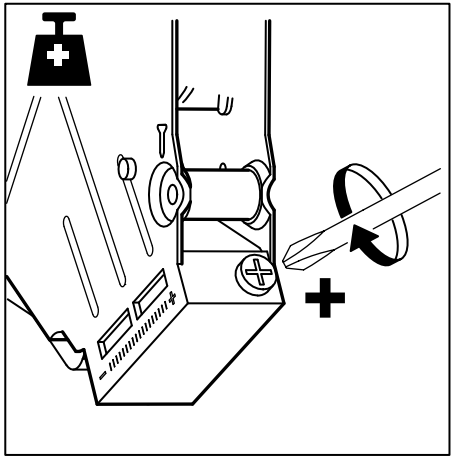
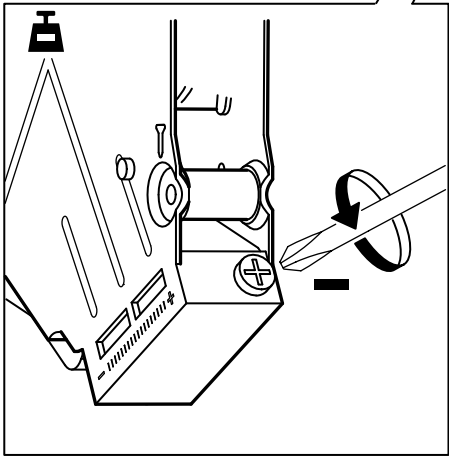
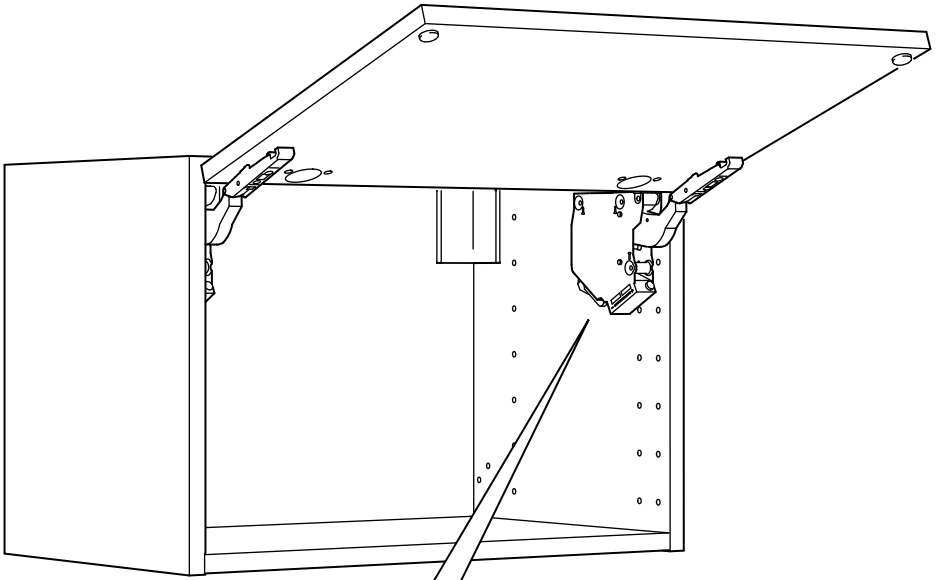

8

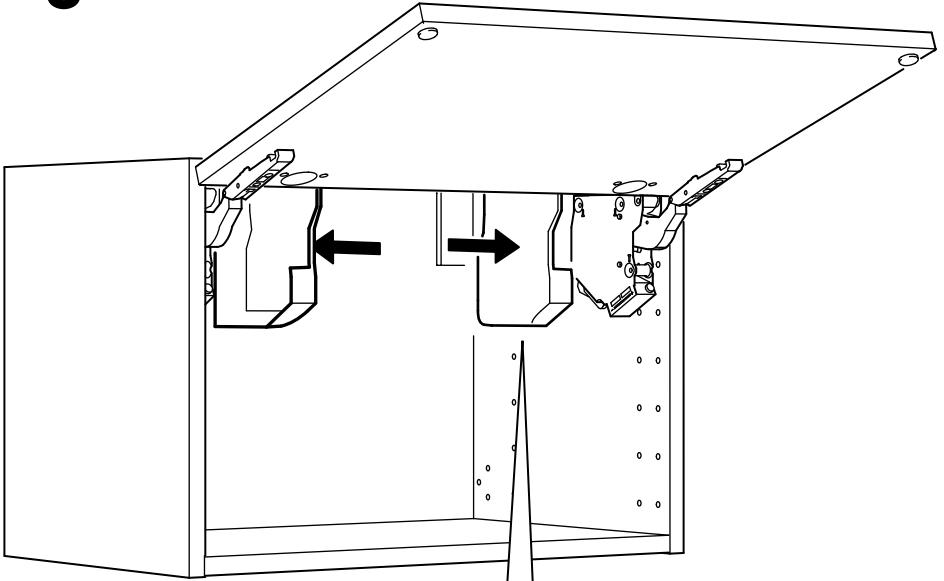

2x

